

***THOMSON***



[tv.mythomson.com](https://tv.mythomson.com)



[tv.mythomson.com/  
pages/faqs](https://tv.mythomson.com/pages/faqs)

# THOMSON STREAMING BOX 260 Pro

## IMPORTANT

Please read this manual carefully before installing and operating the Thomson Streaming Box 260 Pro. Keep this manual handy for further reference. Illustrations in this manual are for reference only. Actual product features or appearance may vary without prior notice.

## Contents

1. Safety & Product Information .....	4
1.1 Markings on the product.....	4
1.2 Simplified EU Declaration of Conformity .....	5
1.3 Apps and Performance.....	5
1.4 Data Protection .....	5
1.5 Accessibility .....	5
2. Introduction .....	6
3. Streaming Box.....	6
3.1 Front Panel.....	6
3.2 Rear Panel .....	6
3.3 Remote Control.....	7
4. Installation.....	8
4.1 Packaging Content.....	8
4.2 Setup.....	8
4.3 LAN .....	9
4.4. Reset .....	10
4.5. Optional .....	10
4.6. Remote Control Pairing.....	10
4.7. First Installation.....	11
5. Home Screen.....	12
5.1 Home .....	12
5.2. Google account.....	13
5.3 Apps .....	13
5.4. Library .....	14
5.5. Google TV search .....	15
5.6. Notification .....	16
6. Settings .....	16
7. Connection of Bluetooth Devices .....	17

8. The functionality of the Star button on the remote control .....	18
9. Cast Content (Google Cast).....	19
10. Hey Google-Voice control.....	19
11. Display Settings / Advanced display settings .....	19
11.1 Allow game mode On/Off:.....	19
11.2 Preferred dynamic range format:.....	20
11.3 Allow dynamic range formats .....	20
12. Sound Settings .....	21
12.1 Audio options.....	21
12.2 Surround sound settings.....	22
13. USB Playback.....	23
14. Updates.....	24
15. Questions & Answers.....	24
16. Technical Specifications.....	25
16.1. Audio & Video .....	25
16.2 System & Memory.....	25
16.3 Ports.....	25
16.4 Wireless Connectivity .....	26
16.5 Compatibility .....	26
17. European Agency Information.....	27



# 1. Safety & Product Information

Your device has been carefully checked and packed before shipping. When unpacking it, make sure that all the parts are included, and keep the packaging away from children. We recommend that you keep the carton during the warranty period, to keep your device perfectly protected in the event of repair or warranty.

Please read the instructions before operating the device and keep them for later use. The product needs to be installed in accordance with national regulations.

## 1.1 Markings on the product

The following symbols are used on the product as a marker for restrictions and precautions, and safety instructions. Each explanation shall be considered where the product bears a related marking only. Note such information for security reasons.



Please place the device at a well-ventilated location on a flat, firm, and stable surface.

Unplug the unit in case of prolonged non-use. If the power cord is damaged, it must be replaced with the power adapter 12 V 1 A. Please contact the After Sales Service to avoid possible danger.

- Use only the supplied power adapter.
- Do not use other adapters.
- The power adapter serves as the disconnect device.
- The socket outlet must be easily accessible.



NOTICE: To prevent electric shock, do not expose this device to rain or moisture and protect it from high temperature, humidity, water, and dust. Do not use the unit in damp or cold locations.



In case the unit needs to get repaired, please go to the website: [tv.mythomson.com/pages/support](http://tv.mythomson.com/pages/support) and contact the After Sales Service.



To prevent the spread of fire, always keep candles or other open flames away. Keep the device away from direct sunlight.



AAA

There is a danger of explosion if the batteries are incorrectly replaced. Replace them only with the same or equivalent types. The used batteries must be disposed of safely. Throw them in appropriate rubbish bins to protect the environment.

Risks of explosion if the battery is replaced by an incorrect type:

- Replacement of a battery with an incorrect type that can defeat a safeguard (for example, in the case of some lithium battery types)
- Disposal of a battery into fire or a hot oven, or mechanically crushing or cutting of a battery, which can result in an explosion
- Leaving a battery in an extremely high temperature surrounding environment that can result in an explosion or the leakage of flammable liquid or gas
- A battery subjected to extremely low air pressure that may result in an explosion or the leakage of flammable liquid or gas.



Equipment with this symbol is a Class II or double-insulated electrical appliance. It has been designed in such a way that it does not require a safety connection to electrical earthing.



This marking indicates that this product must be properly disposed of throughout the EU in accordance with Directive 2012/19/EU (WEEE) and may not be disposed of with other household waste. Please recycle it responsibly to help with the sustainable reuse of material resources. Please return it to a collection system or contact the retailer where you purchased the product.

According to the Battery Act, end users are legally obliged to return old batteries. Please do not throw used batteries to household waste but return them to a collection system for used batteries.

**Figures and illustrations in this user manual are provided for reference only and may differ from the actual product appearance. Product design and specifications may be changed without notice.**

## 1.2 Simplified EU Declaration of Conformity

Hereby, StreamView declares that the radio equipment type product device Streaming Box is complying with Directive 2014/53/EU. The full text of the EU declaration of conformity is available at the following internet address: [tv.mythomson.com/pages/support](http://tv.mythomson.com/pages/support)

Intended for indoor use only in EU member states and EFTA states.



## 1.3 Apps and Performance

Download speed depends on your Internet connection. Some apps might not be available in your country or region. Streaming membership may be required. Netflix is available in selected countries. More information at [www.netflix.com](http://www.netflix.com). The availability of the language for Google Assistant depends on Google Voice Search support.

## 1.4 Data Protection

The application providers and the providers of the services may collect and use technical data and related information, including but not limited to technical information about this device, system and application software and peripherals. They may use such information to improve products or to provide services or technologies, which do not personally identify you. Additionally, some third-party services, already provided in the device or installed by you after purchasing the product, may request a registration with your personal data. Some services may collect personal data even without providing additional warnings. StreamView cannot be held liable for a possible breach of data protection by third-party services.

## 1.5 Accessibility

To enable accessibility features, press the  (**Settings**) button on your remote, select **Accessibility**, and then press **OK** button to enter.

You can turn on options like Talkback, Text to speech, Text scaling, Bold text, Color correction, Accessibility shortcut, Keyboard accessibility, Switch Access, Audio description, Captions, High contrast text. Select the feature you need and press **OK** to activate it.

## 2. Introduction

The Thomson Streaming Box 260 Pro upgrades your TV to a Smart TV and brings the experience of Android, known from mobile phones to your TV. You can download apps, such as streaming services, games, TV media centers and thousands of more from Google Play. Ask Google to quickly find YouTube videos, the latest blockbuster, check the internet for weather or other content. Cast your photos, videos and music from mobile devices to your TV with Google Cast built in.

## 3. Streaming Box

### Caution:



If you want to connect the device to a TV, make sure that both the TV and the device are turned off before making any connection. After the connection is done, you can turn on the units and use them.



Do not touch or be close to the HDMI, USB terminals, and prevent electrostatic discharge to disturb these terminals while in USB operation mode, or it will cause the TV to stop working or cause an abnormal status.

Note: The actual position and arrangement of ports may be different from model to model.

### 3.1 Front Panel

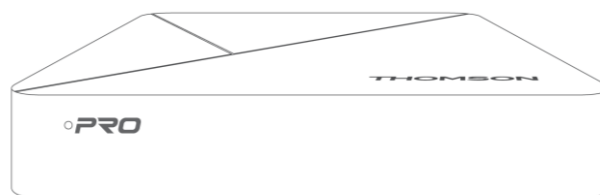



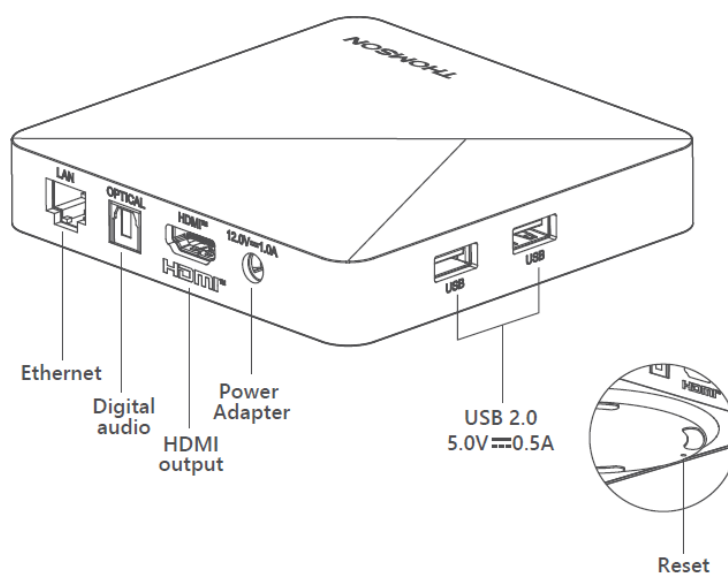





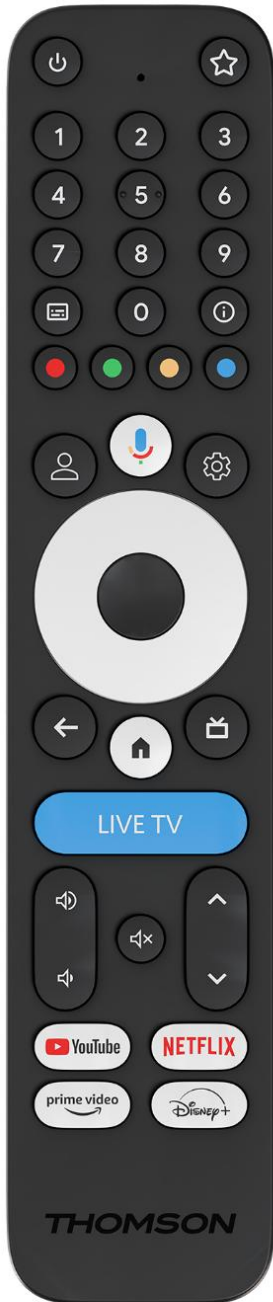











### 3.2 Rear Panel



Note: The actual position and arrangement of ports may be different from model to model

### 3.3 Remote Control



	Standby: Quick Standby / Standby / On
	Press and hold this button to determine the shortcut function of this button. Briefly press the Star button to launch the selected favorite app or to select the input source
0-9	Numeric Buttons: Enter a number or a letter in the text box on the screen
	Subtitles: Turns subtitles on and off (where available)
	Info: Displays information about on-screen content
	Colored Buttons: functions in various apps: follow on-screen instructions
	Profile Switch: Switch between multiple Google profiles
	Microphone: Activate the Google Assistant
	Settings: Display Live TV Settings menu (in Live TV mode), display available setting options such as sound and picture
	Direction button (D-pad): Navigating in the menu, setting options, moving the focus or cursor, etc.
	OK: Confirms selections
	Back/Return: Return to previous menu screen, go one step back, close windows, close teletext (in Live TV-Teletext mode). Exit the playback of multimedia files and return to the MMP (Multi Media Player) overview menu
	Electronic program guide
	Home: Opens the Home Screen
LIVE TV	Launch the Live TV application ( if available for your country)
	Volume +/-: Controls the Sound Volume of the TV
	Program +/-: Zapping the single TV/radio channels. Scrolls the channel list page by page when the channel list is displayed on the TV screen
	Mute: Completely turn off the volume of the TV
	Launch the YouTube application
	Launch the Netflix application
	Launch the Prime Video application
	Launch the Disney + application

## 4. Installation

### 4.1 Packaging Content

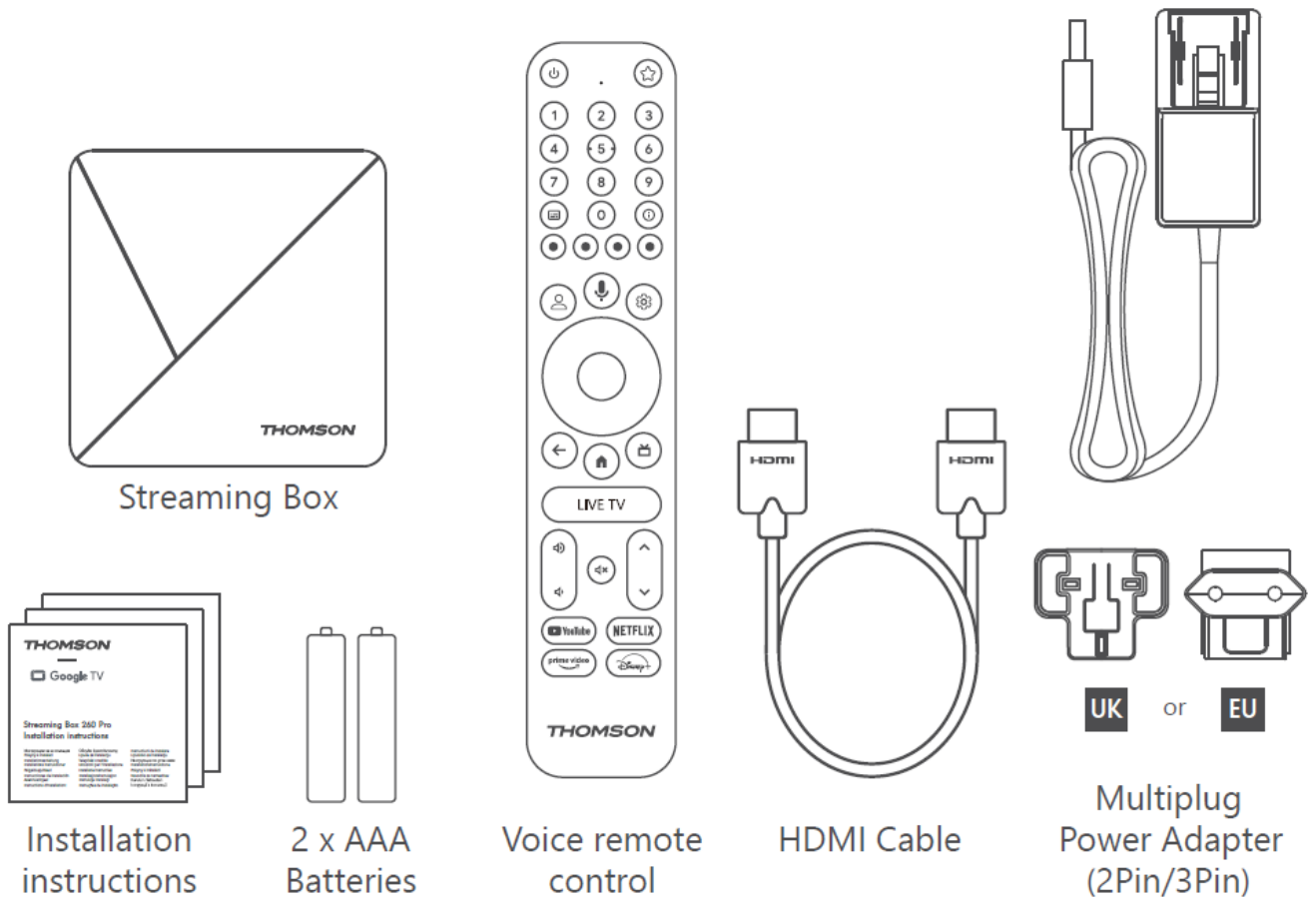

### 4.2 Setup

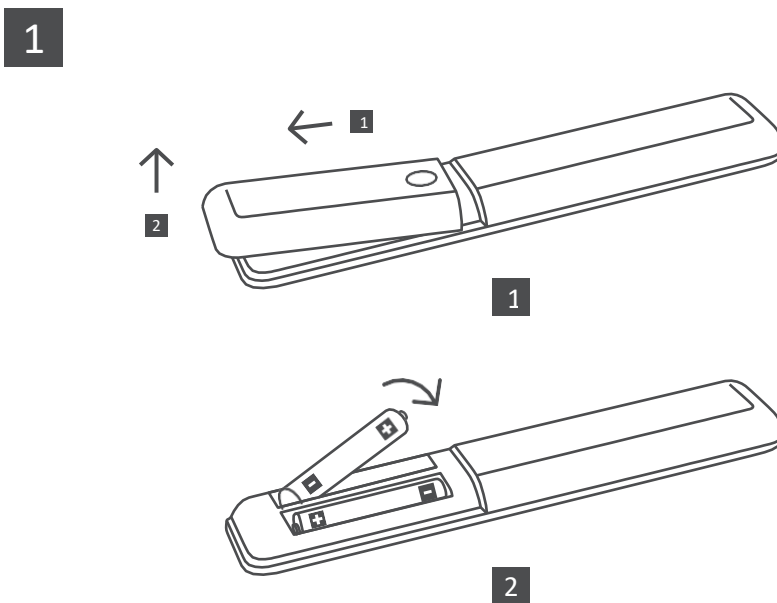

2

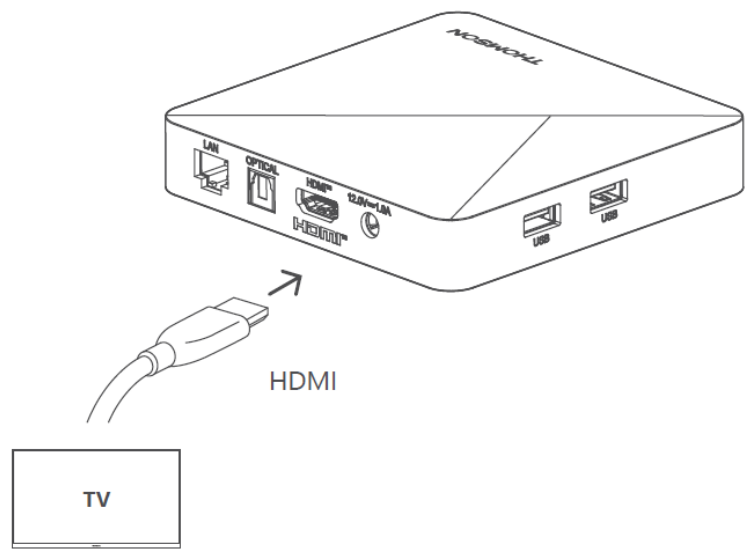

3

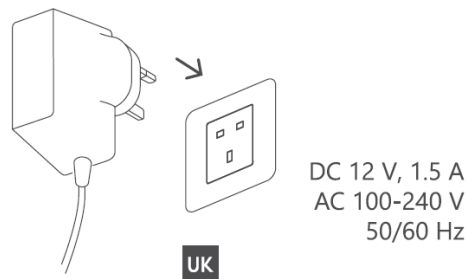
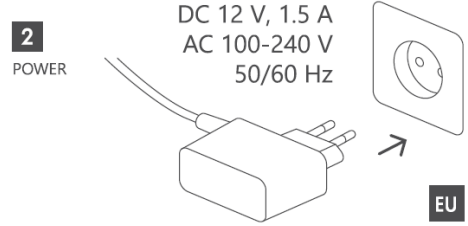
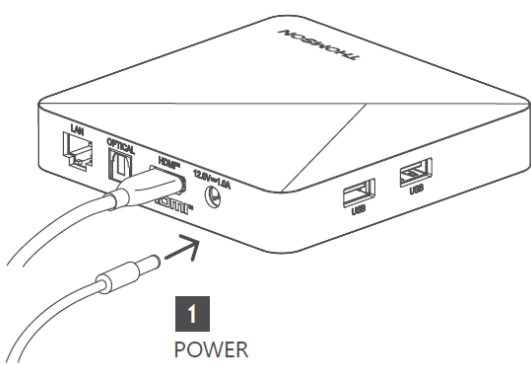

### 4.3 LAN

4

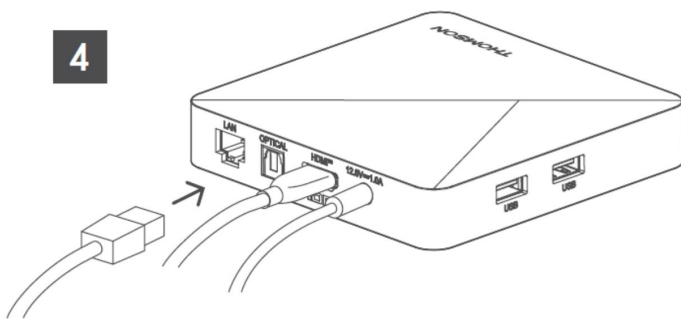

If an Internet connection via LAN is not available, the initial installation will prompt you to connect to the Internet via WLAN.

#### 4.4. Reset

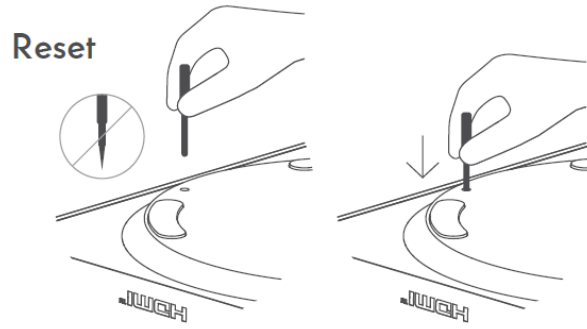

#### 4.5. Optional

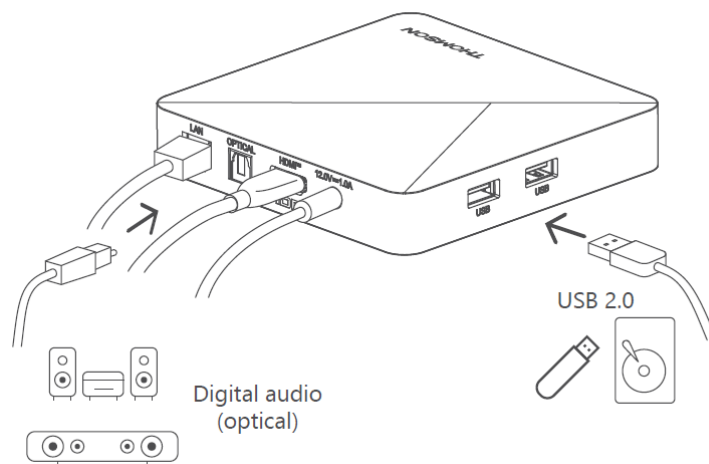

#### 4.6. Remote Control Pairing

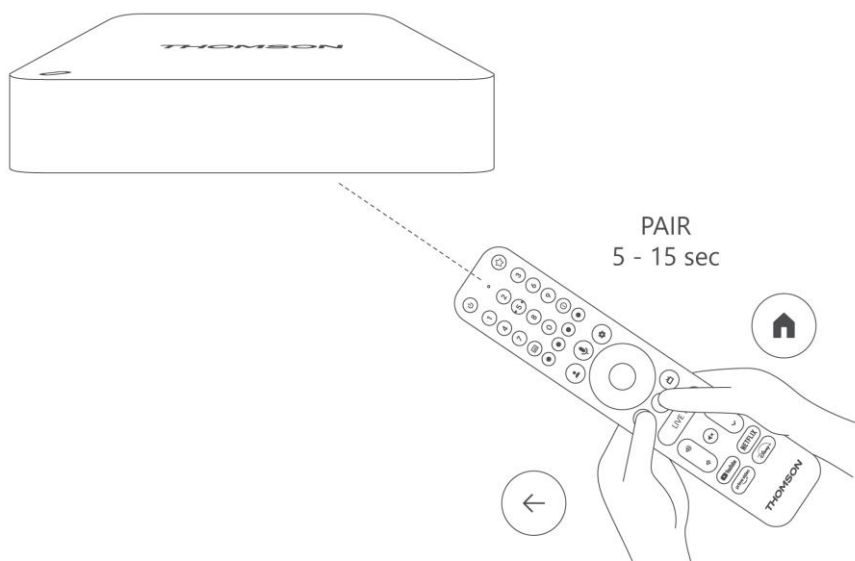

Turn on the TV and the Streaming Box and follow the on-screen instructions to pair the remote control.

#### **4.7. First Installation**

After you have successfully paired the remote control, select the installation language and your region, and follow the installation instructions on your screen.

You can set up your Thomson Streaming Box 260 Pro via the Google Home application on your mobile (phone or tablet) or manually by selecting the "Set up on TV instead" option at the bottom of the screen.

**Note:**

A Google account is required to set up the Thomson Streaming Box 260 Pro.

You must be signed in to your Google account to access the Google Play Store, Hey Google and your favorite streaming applications.

If you do not have a Google account or want to create a shared account, you must register it before installing the Thomson Streaming Box 260 Pro on your computer or smartphone.

You can create a Google account by visiting the following website:  
<https://accounts.google.com/signup>

After completing the initial installation of your Thomson streaming device, the Google TV home screen will be displayed.

Please note that the illustrations of the menu screens shown in this user guide are for reference only and they may differ in your country.

## 5. Home Screen

### 5.1 Home

From the Home screen, you can launch any installed application, watch a movie from various Streaming applications or enter Settings menu of your Thomson Streaming Box 260 Pro. Also, you can exit the operation of any application at any time and return to the Home screen by pressing the Home button on the remote control.

In the first (Recommended for you) row, the streaming content of the streaming applications installed on your TV will be suggested according to your search criteria in your search history.

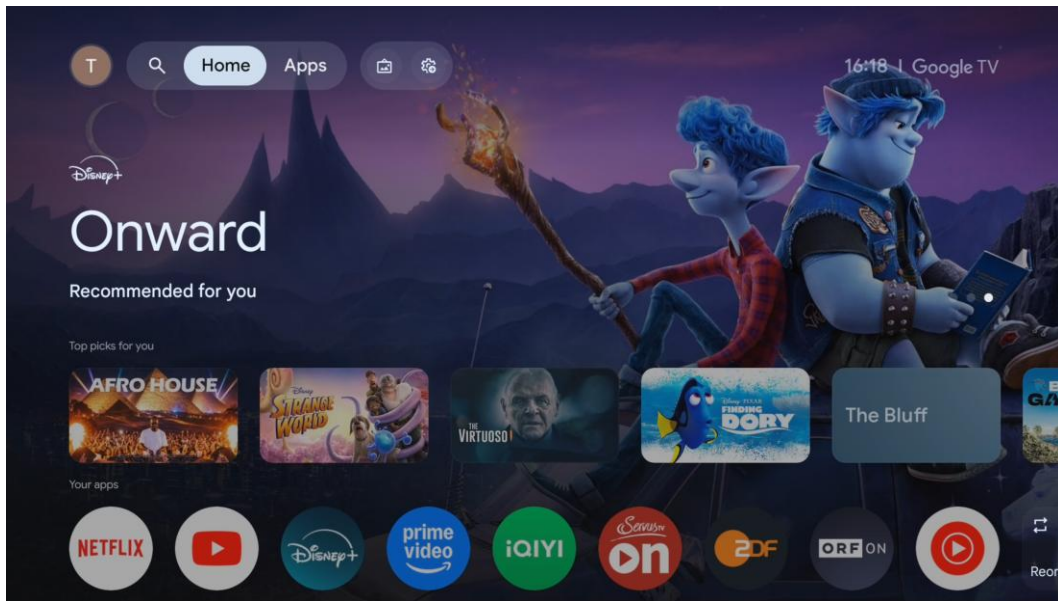

Note: Depending on the settings of your TV set and your country selection during the initial setup, the Home menu may contain different elements.

The second (Your apps) row is the row of applications. The most important applications for streaming services such as Netflix or YouTube can be found in this first line.

Select the application with the directional buttons on your remote control and confirm your selection with the OK button to start the selected application.

Select the application and press and hold the OK button to remove the selected application from the first row of favorites, move it to a new position or launch it.

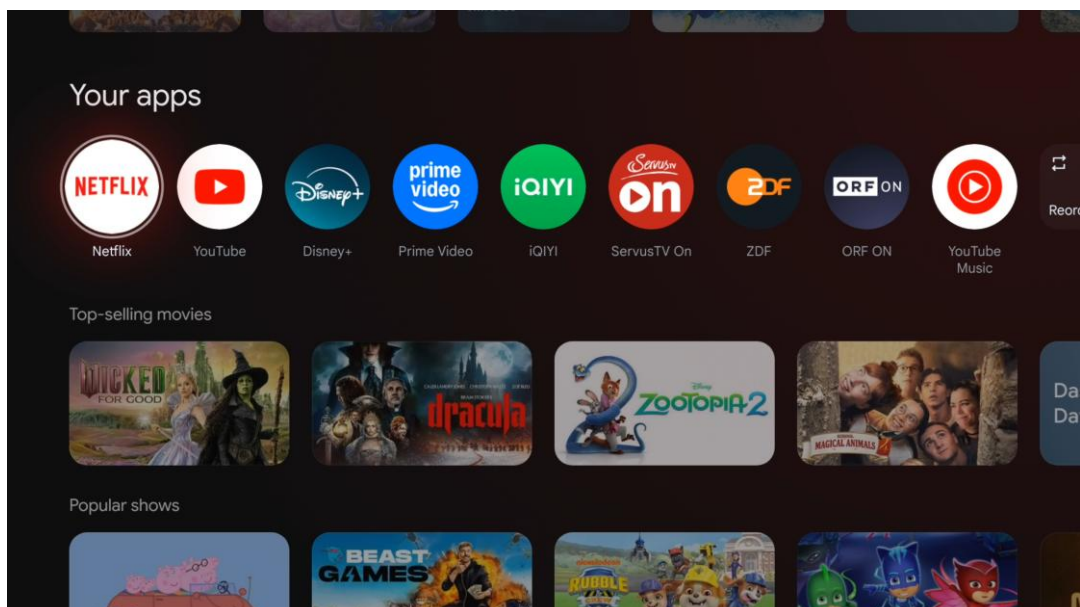

On the penultimate and last position in this row you will find boxes with the options "Reorder" and "Add apps". Select these function options to reorder the applications in this row or to add new application to this Favorite applications row.

Further down on the home screen, you will find additional channels displayed by genre or streaming content category.

## 5.2. Google account

Navigate to your profile icon at the top left corner and press "OK".

Here you can change your profile settings, add new Google account, or manage already existing accounts.

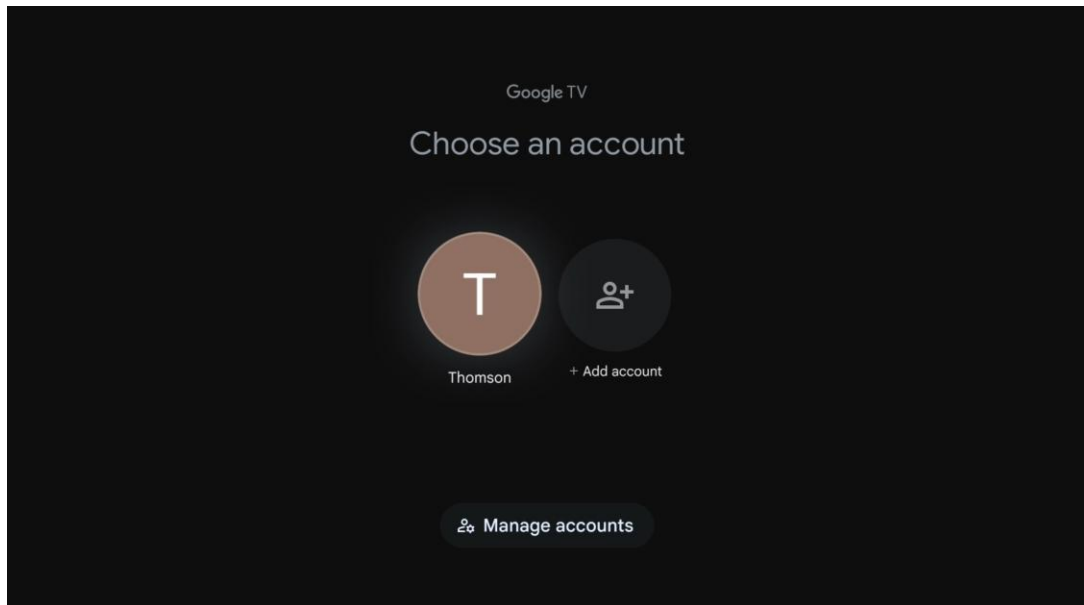

## 5.3 Apps

Select the Apps tab on the Home screen to display applications installed on your TV. Highlight a search bar to type in the name of an application you wish to install from Google Play Store.

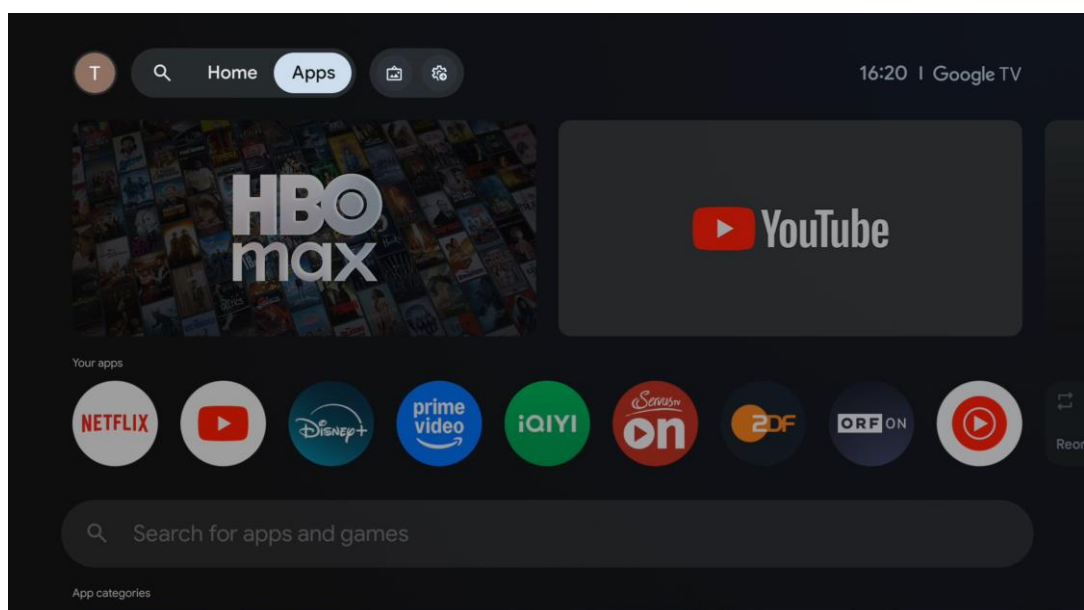

**Note:** Some apps work only in your own network. These apps are not open internet services but only in-house solutions for several TV sets in the same household. The operation of these applications can therefore be determined by your IP TV or Network operator.

Some apps are available for downloading according to Geo-Location. This means that Geo-Location dependent applications are only available in the Google Play store according to the Geo-Location rules and cannot be downloaded and installed in different countries

Some apps that are available for mobile devices such as smartphones and tablets are for legal reasons not available for download on Google TV devices.

## 5.4. Library

Navigate to your profile icon and select Library in the dropdown menu.

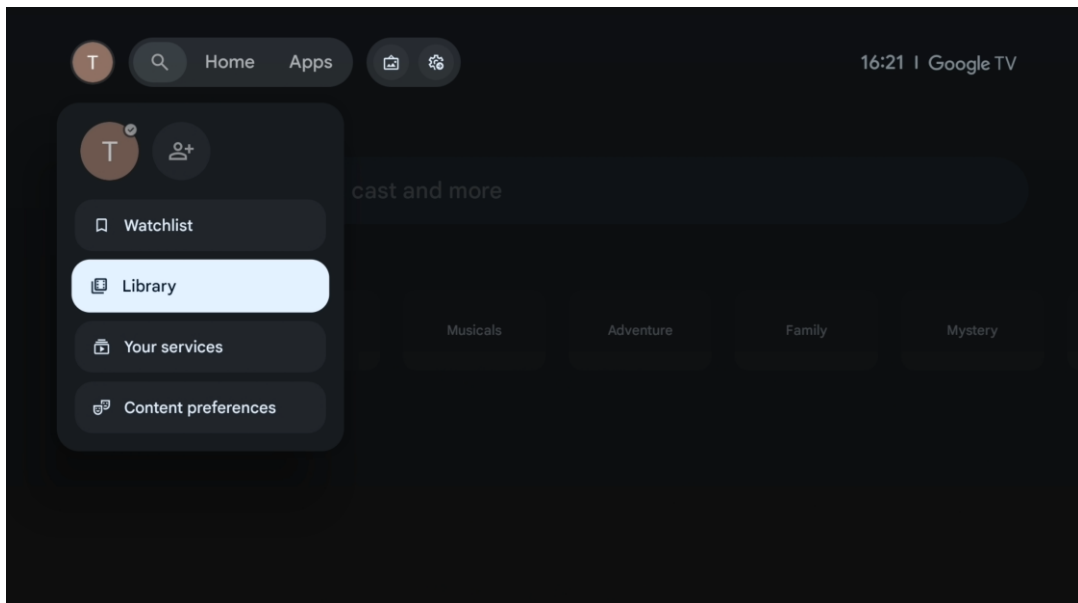

In the Library tab you can play the streaming content you have already purchased or rented on your TV or mobile devices such as your mobile phone or tablet using your Google account.

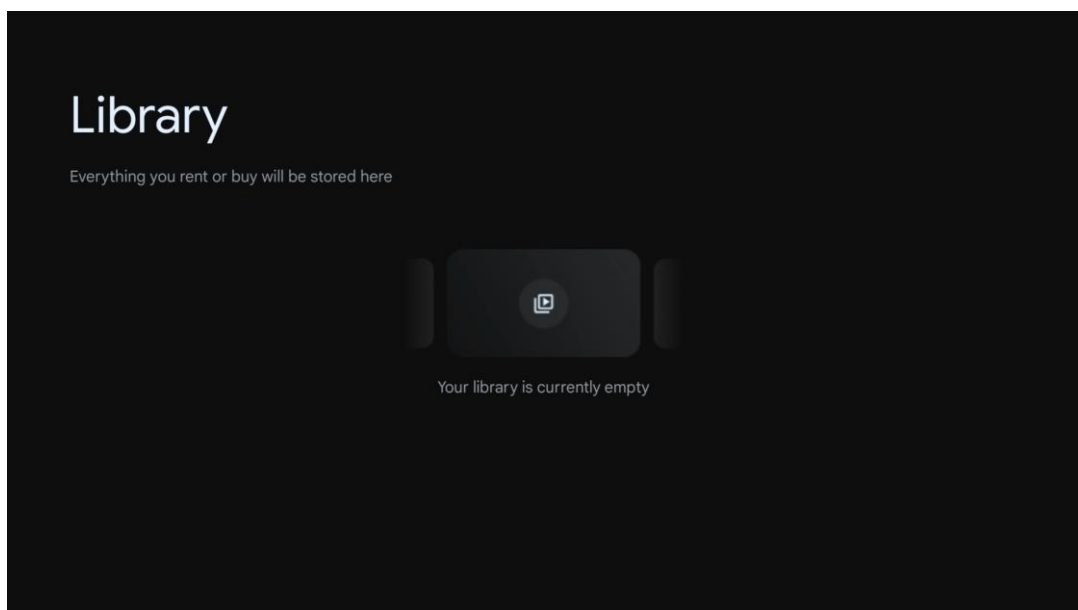

## 5.5. Google TV search

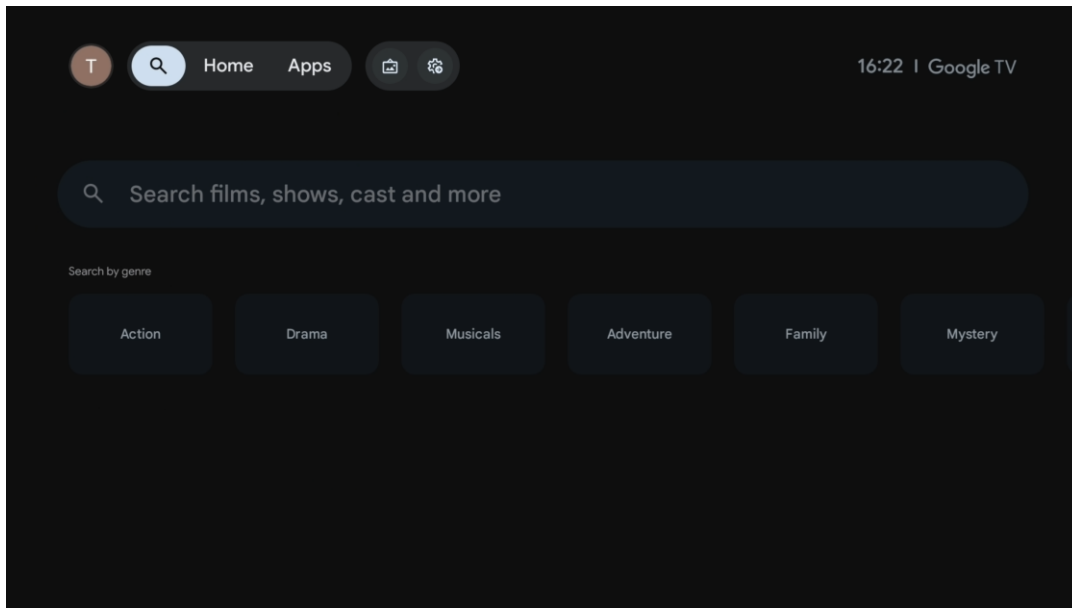

The search tools are located at the top left of the screen. You can either enter a word to start a search using the virtual keyboard or try voice search using the microphone built into your remote control.

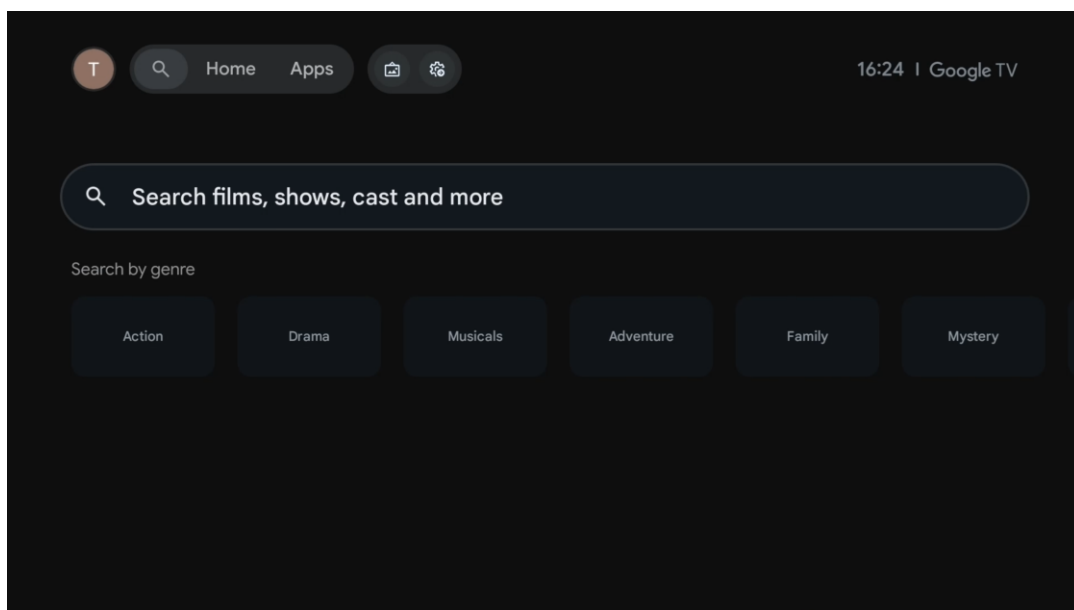

Voice search – Press the microphone icon to start the voice search function. Google voice search field appears at the top of the screen. Ask your question to Google and your TV will answer you. For local search terms it is important that the Menu language of the TV is set to the local language.

Keyboard search – Select the search bar and press “OK”. The virtual Google keyboard will appear on the screen. Type the question you want to get answered.

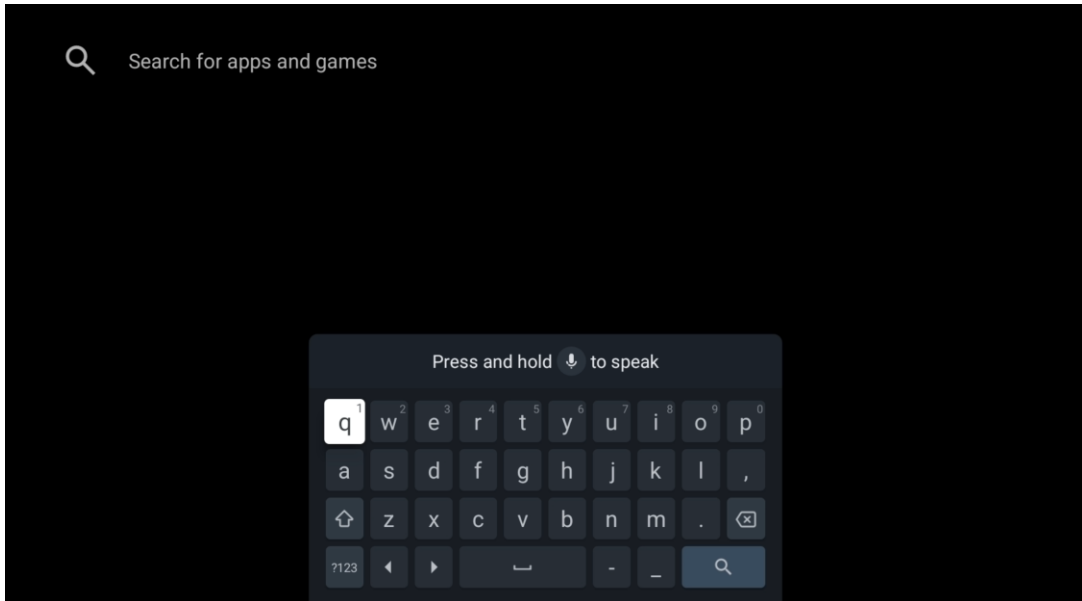

## 5.6. Notification

Notification bubble appears only when there are one or more unread notifications. To check them, please, navigate to the Settings icon, the submenu will be opened. At the bottom of the submenu, you will be able to find all the latest notifications.

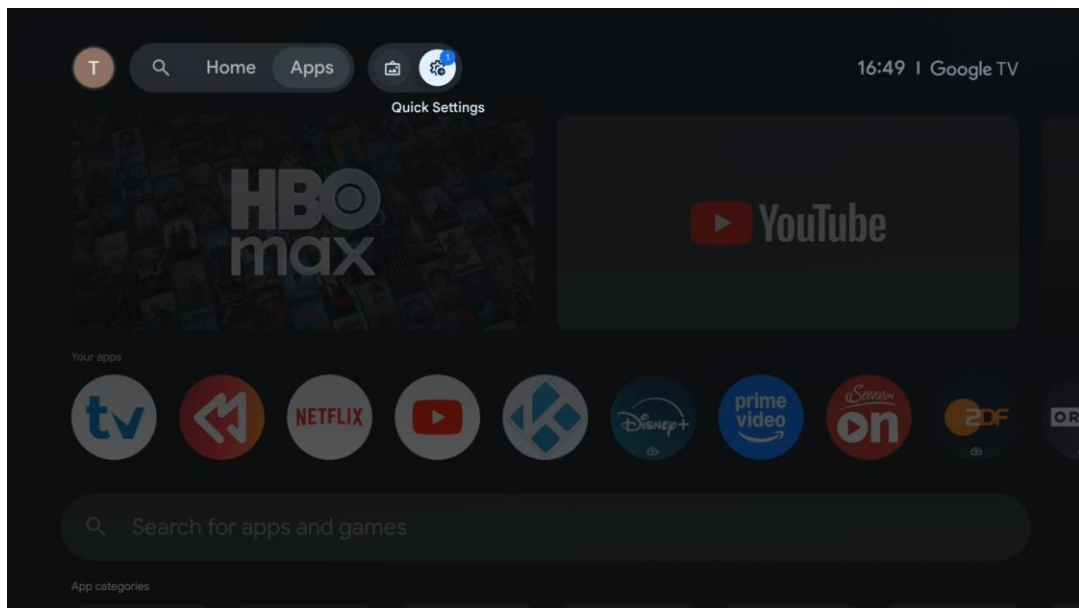

## 6. Settings

To enter full list of available settings, please, enter the Home Screen, by pressing (icon) Home Screen button, and navigate to the (icon) Settings button at the right top corner.

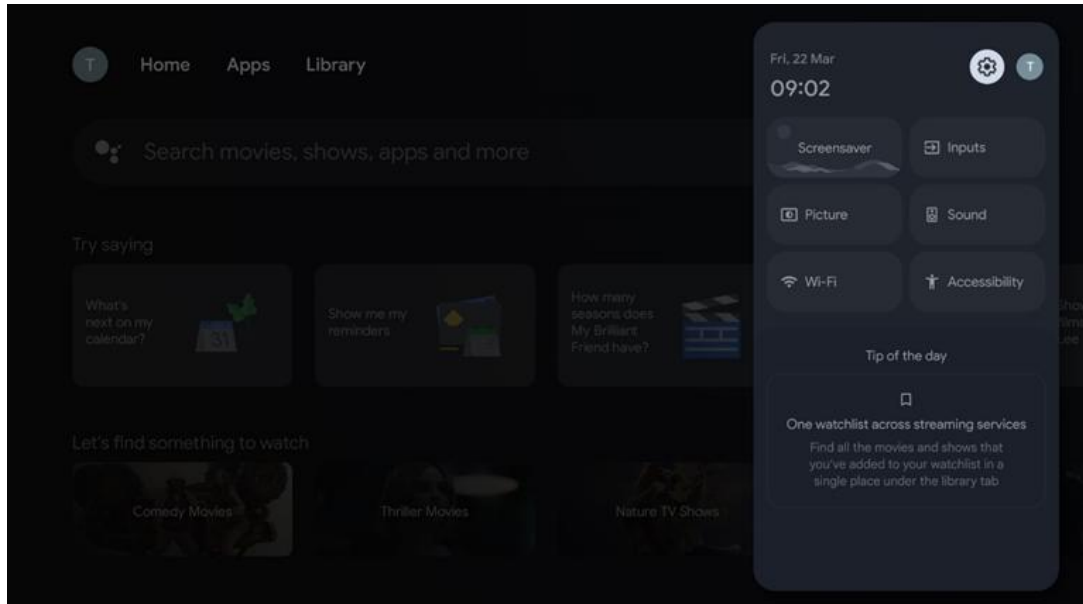

## 7. Connection of Bluetooth Devices

### Remotes and accessories

In this menu you can connect audio devices such as headphones and speakers as well as input devices such as gamepads, mouse, or keyboard via Bluetooth to the Thomson Streaming Box 260 Pro. You can also set up the remote control so you can control Power On/Off, Volume +/- or Input Selection of the connected devices (TV, AV Receiver or Soundbar) with the THOMSON remote control. Press the Settings button on the remote control and press OK to open the Settings menu. Select Bluetooth and press OK.

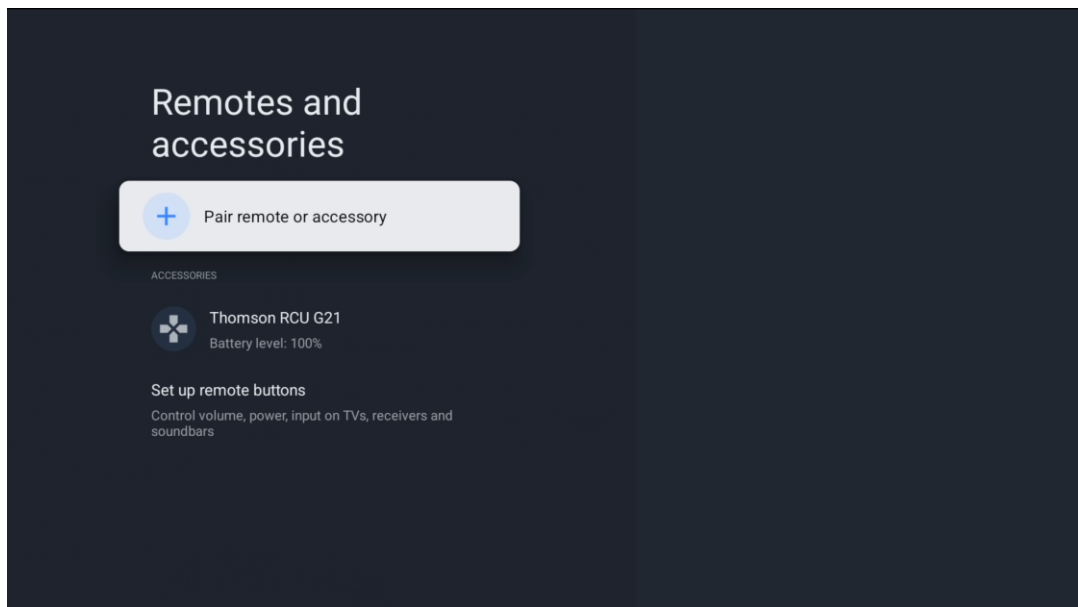

### Pair remote or accessory

Make sure that Bluetooth pairing mode is activated on the device you want to connect to the Thomson 260 Pro. Select menu option **Pair remote or accessory** and press OK. Bluetooth device will be listed on the right side. Select the device and press OK to start the pairing process.

### Accessories

In the menu you can manage Bluetooth connected devices such as remote control.

## Set up remote buttons

Select menu option **Set up remote buttons** and press OK. There are two submenus in the Set up remote buttons menu:

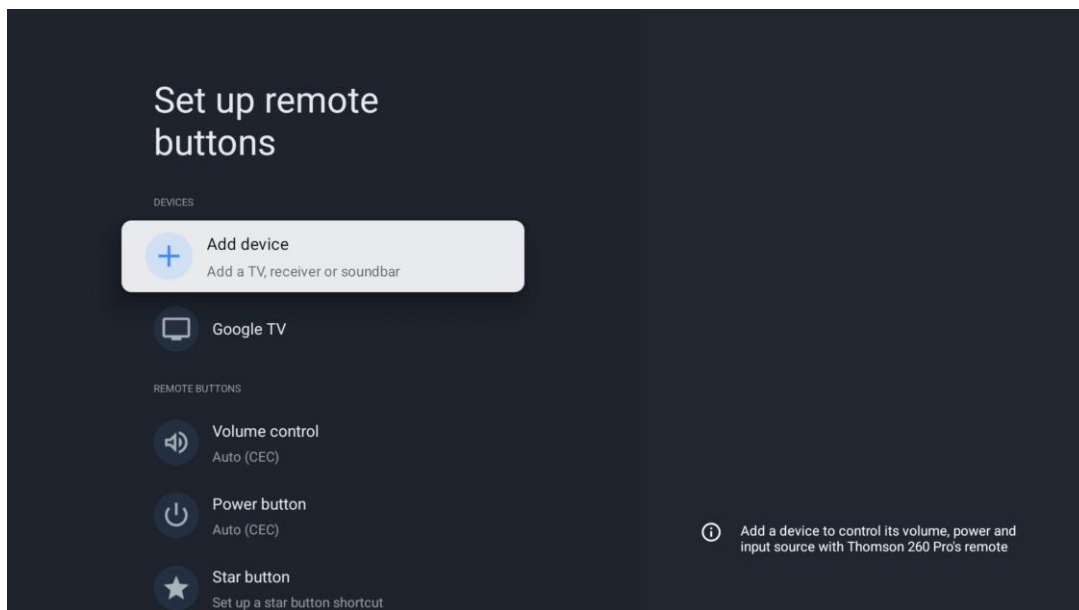

## Remote Buttons

In this submenu you can configure the operation of your Thomson RCU. You can set which operating functions you want to continue to operate with the original remote control of the connected device (TV, AV receiver or soundbar) and which you want to operate with the Thomson remote control, or functionality of the Star button.

## 8. The functionality of the Star button on the remote control

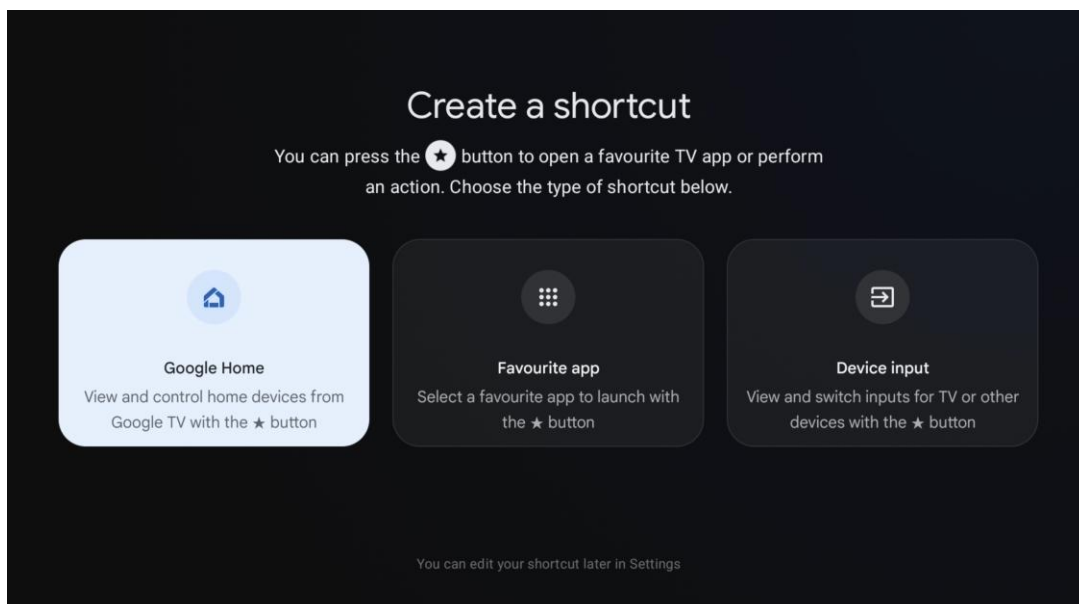

To set the functionality of the Star button, press and hold the Star button. A dialog screen will appear on the screen where you can use the Star button function as a direct launch of the selected installed application or as an input selection. Follow the instructions on the dialog screen to configure the Star button function correctly. After the functionality of the Star button is configured, briefly press this button to directly launch the selected application installed on your device or to select the specified input.

## 9. Cast Content (Google Cast)

The Thomson Streaming Box 260 Pro has Google Cast built in. You can cast videos, music or other content from your smart phone, tablet, or computer to your TV.

1. Please make sure that your phone, tablet, or computer is in the same network as your Thomson 260 Pro.
2. Open the app that supports casting, e.g., YouTube.
3. Select the video and click the cast icon.
4. Select the Thomson 260 Pro and press OK.

Playback will start automatically. Please note that not every application for streaming video content supports Google Cast.

## 10. Hey Google-Voice control

The Thomson Streaming Box 260 Pro supports the "Hey Google" function. The "**Hey Google**" function can be activated by pressing the microphone button on the remote control.

You can perform various operations on the box using the Hey Google function, for example, you can adjust the volume percentage, mute and unmute the volume or launch various applications. You can search for various information from the Internet, e.g. "**What will the weather be like tomorrow**", or search for movies, series or videos in applications from streaming services such as Netflix, Prime Video, Disney+ or YouTube.

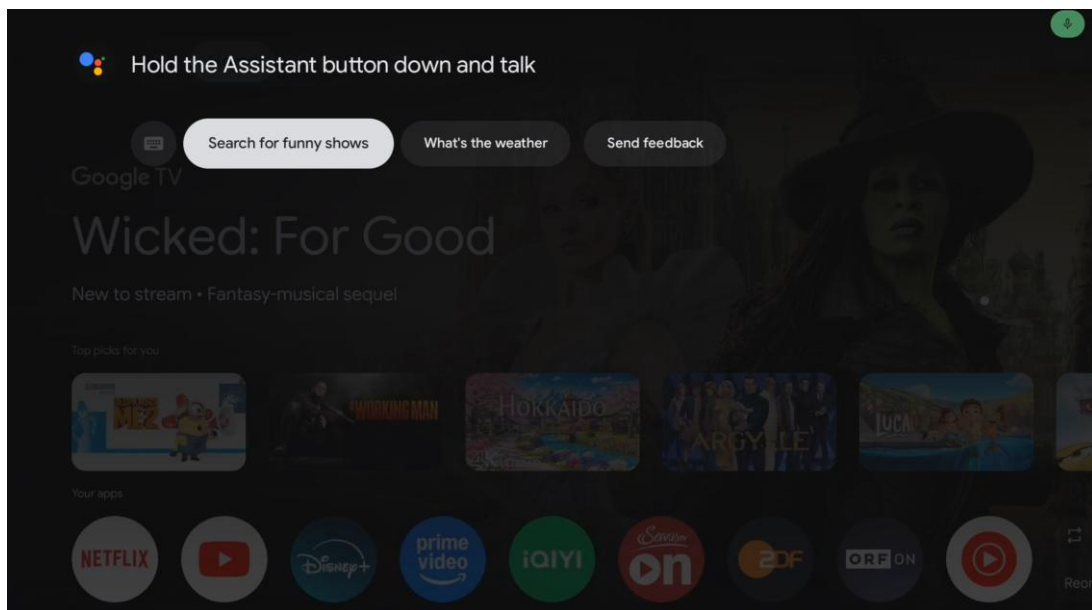

## 11. Display Settings / Advanced display settings

Press the Settings button on your remote control or select the Settings icon on the Home Screen and open Display and Sound -> Advanced display settings.

The following display format settings are available:

### 11.1 Allow game mode On/Off:

When turned **On**, the streaming box optimizes the display for gaming by reducing input delay and improving responsiveness. This provides smoother experience when using game consoles or interactive applications.

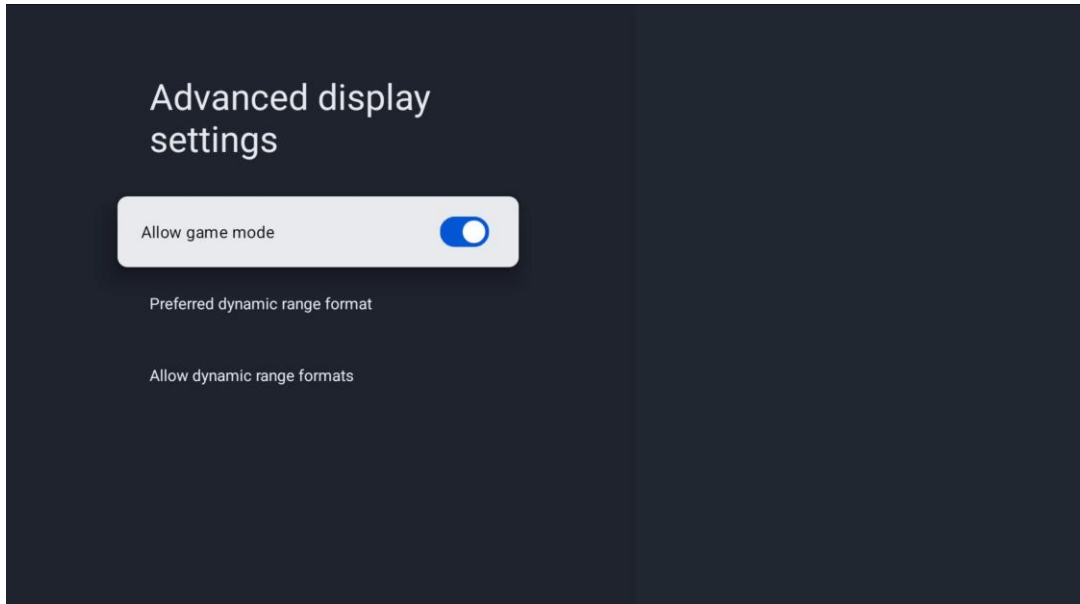

When turned **Off**, the device uses standard display processing, which may be better suited for regular video playback and streaming content.

### 11.2 Preferred dynamic range format:

The **Preferred Dynamic Range Format** option allows you to select how the streaming box handles dynamic range settings for video playback, such as HDR (High Dynamic Range) or standard SDR content.

This setting helps ensure the best picture quality depending on your TV capabilities.

#### Available Options

- **System-Preferred Conversion**  
When selected, the streaming box automatically chooses the most suitable dynamic range format based on the connected TV and the content being played. This is the recommended option for most users.
- **Force Conversion**  
When selected, the streaming box forces video output to be converted into a fixed dynamic range format, regardless of the original content or TV recommendation. This option may be useful for compatibility with certain displays or specific user preferences.

### 11.3 Allow dynamic range formats

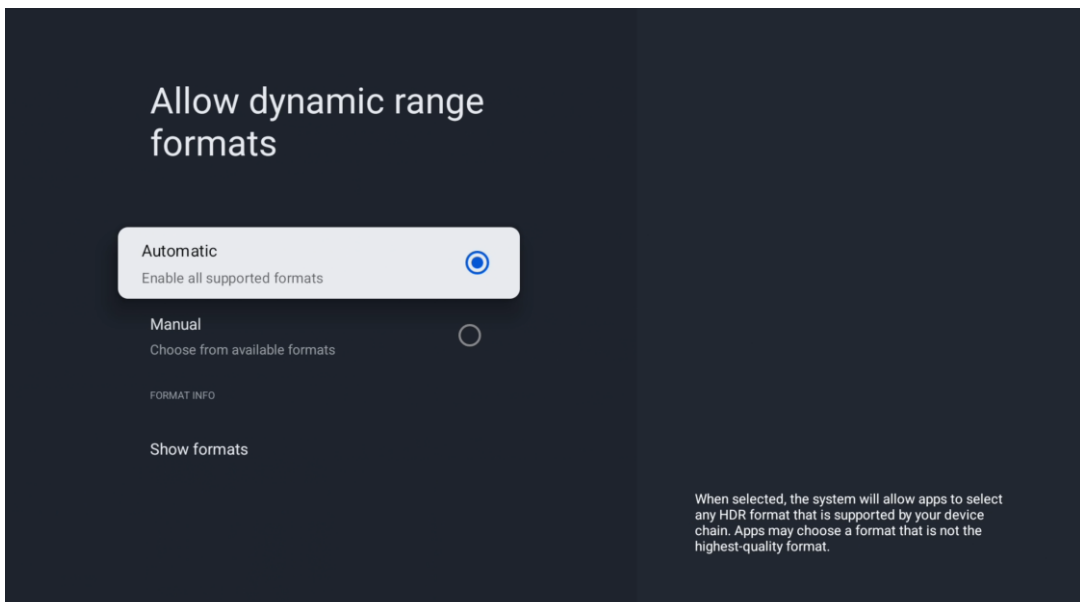

The **Allow Dynamic Range Formats option** controls which dynamic range formats the streaming box is allowed to use when displaying video content. Dynamic range formats such as HDR improve contrast, brightness, and colour detail for a more realistic viewing experience. This setting can be configured automatically or manually depending on user preference.

### Available Options

#### Automatic (Enable All Supported Formats)

When selected, the streaming box automatically enables all dynamic range formats supported by the connected TV. This ensures the best possible picture quality without requiring manual adjustments.

#### Manual (Choose from Available Formats)

When selected, the user can manually choose which dynamic range formats are allowed. This option is useful if certain formats cause compatibility issues or if the user prefers to limit output to specific formats.

- **Automatic (Enable All Supported Formats)**

When selected, the streaming box automatically enables all dynamic range formats supported by the connected TV. This ensures the best possible picture quality without requiring manual adjustments.

- **Manual (Choose from Available Formats)**

When selected, the user can manually choose which dynamic range formats are allowed. This option is useful if certain formats cause compatibility issues or if the user prefers to limit output to specific formats.

## 12. Sound Settings

### 12.1 Audio options

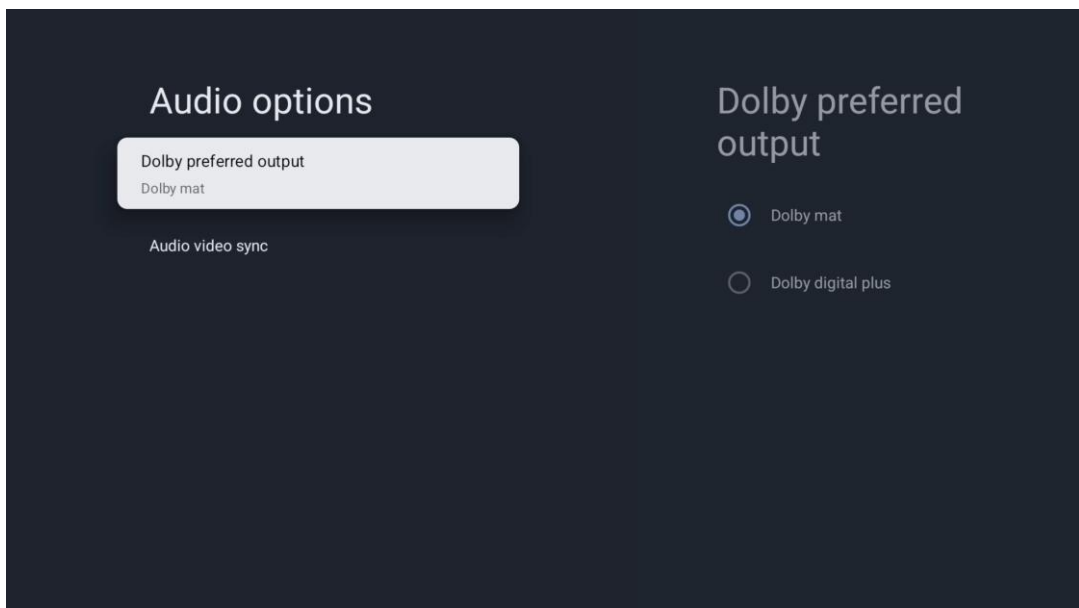

#### Dolby preferred output

The **Dolby preferred output** option allows you to select the preferred Dolby Audio format used by the streaming box when playing supported content. This setting helps optimize audio quality and compatibility depending on the connected audio system, such as a TV, soundbar, or AV receiver.

## Available Options

- **Dolby MAT**

When selected, the streaming box outputs audio using **Dolby MAT (Metadata-enhanced Audio Transmission)**. This format supports high-quality audio delivery and is commonly used for Dolby Atmos playback through compatible sound systems.

- **Dolby Digital Plus**

When selected, the streaming box outputs audio using **Dolby Digital Plus**, a widely supported surround sound format. This option provides excellent audio quality and is recommended for devices that do not support Dolby MAT.

## Audio video sync

The **Audio video Sync** function allows you to adjust the timing of the audio output so that it matches the video playback correctly.

In some cases, audio may play slightly earlier or later than the video, causing a noticeable delay (for example, when voices do not match lip movement). This feature helps correct that issue.

When this option is opened, a visual guide is displayed on the screen. Use the **Left** and **Right** buttons on the remote control to advance or delay the audio timing until the sound is properly synchronized with the video.

This setting is especially useful when using external sound systems such as soundbars or AV receivers.

## 12.2 Surround sound settings

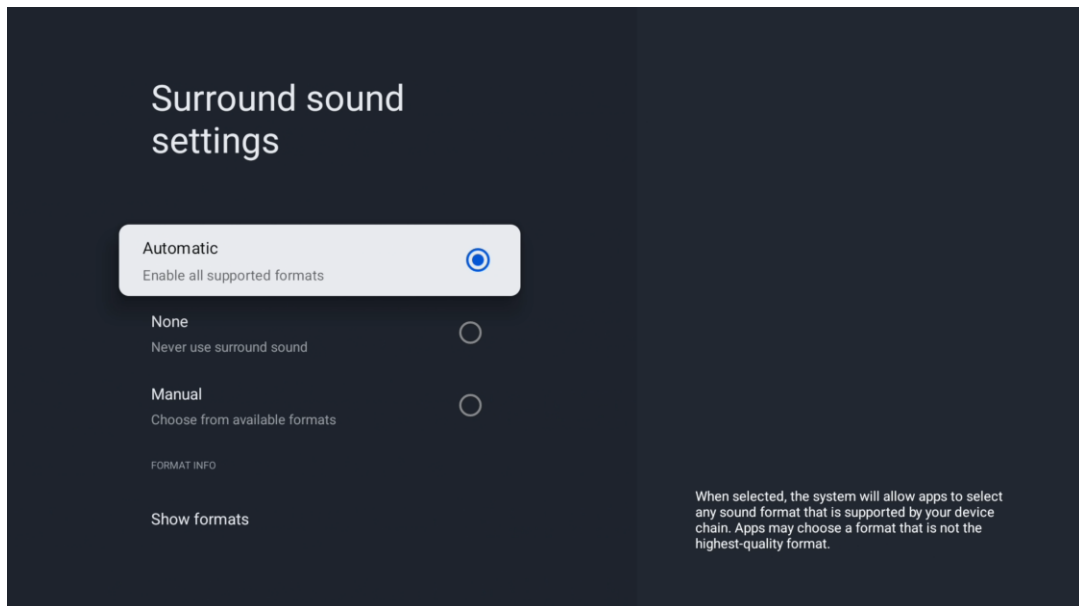

The **Surround Sound Settings** option allows you to control how the streaming box outputs surround sound audio formats when supported content is played.

Surround sound enhances the listening experience by providing multi-channel audio, especially when using a compatible TV, soundbar, or AV receiver.

## Available Options

- **Automatic** (Enable all supported formats)  
When selected, the streaming box automatically enables all surround sound formats supported by the connected audio device. This is the recommended option for most users to achieve the best audio quality.
- **None** (Never use surround sound)  
When selected, the streaming box disables surround sound output and plays audio only in standard stereo format. This option is recommended for devices that do not support surround sound or when troubleshooting audio issues.
- **Manual** (Choose from available formats)  
When selected, the user can manually choose which surround sound formats are allowed. This option is helpful if certain formats are not fully compatible with the connected audio system or if the user prefers specific audio output settings.

## 13. USB Playback

### Operation of external USB storage devices

Connect an external USB drive (USB flash or external hard disc drive) to one of USB-A ports of the Thomson Streaming Box 260 Pro.

When connecting the USB storage device, press the **HOME** button to display the options. You can play the multimedia content stored on the storage device or expand the internal storage capacity of the Thomson Streaming Box 260 Pro.

### Play Multimedia files from the external storage device

Download a multimedia player app, VLC for Android player, Sun player, or similar from Google Play. Start the installed app and select the file you want to play.

### Expanding the internal storage capacity of the THOMSON Streaming Box 260 Pro:

After you have connected the USB storage device, press the House button on the remote control>>Select the setting icon>>Select the relevant USB flash drive notification [Select to setup]>>Select the option "Set up as device storage" and follow the instructions on the screen.

You can also perform the same operation from the Settings menu.

Settings / System / Storage / Disk / Delete and format as device storage

### Note: USB Port Operation Notice (User Manual Text)

The streaming box is equipped with two USB-A ports for connecting external storage devices such as USB flash drives, HDDs, or SSDs.

Please note that the USB ports provide **limited power output** according to the device's power design.

As a result, some external hard drives or high-performance SSDs with higher power requirements may not be recognized or may not operate reliably when connected directly to the streaming box.

- This is especially true for storage devices that require increased power during startup.
- In addition, connected USB storage devices must be formatted using a compatible file system.

## Supported File Systems

For proper detection and operation, USB storage devices should be formatted as:

- **FAT32**
- **exFAT**

Other file systems (e.g., NTFS) may not be supported.

## Recommendation

To ensure reliable operation, we recommend one of the following:

- Use a **low-power USB storage device** (e.g., USB flash drive)
- Use an external HDD/SSD with its **own power adapter**
- Connect the storage device through a **powered USB hub**

## 14. Updates

Software updates for the Thomson Streaming Box 260 Pro **will be performed automatically**. When updates for installed applications or the operating system become available, a notification will appear on the Home Screen.

Select the notification and press the **OK** button to view the update details.

The Thomson Streaming Box 260 Pro is a **Google-certified device**, ensuring compliance with Google's quality and security standards.

Google system updates and the latest security patches will also be provided regularly to help maintain optimal performance and protection.

## 15. Questions & Answers

What can I do with my Thomson Streaming Box 260 Pro?	The Streaming Box 260 Pro turns your TV into a Smart TV and brings the Android features known from mobile phones to your TV. You can download apps such as streaming services, games, TV media centres and thousands of others from Google Play. For more information, please visit the website <a href="http://tv.mythomson.com">tv.mythomson.com</a>
Do I need a Smart TV to use my Thomson 260 Pro?	No, you don't. The Streaming Box 260 Pro upgrades any TV to a Smart TV.
What connections are required to operate my Thomson 260 Pro?	Connection to TV or Projector: The Streaming Box 260 Pro supports video resolutions up to 4K Ultra HD and should be connected to the TV or projector using the high-quality HDMI cable.  Internet connection: You can connect to the Internet either via Wi-Fi or LAN cable.  See chapter 4.2 for information on optional connections, e.g. to audio devices and USB devices.
If hands-free voice control is not responding	Check network status. Check the streaming device is on unmute state. (Microphone is switched on.) Check that the built-in microphone is mechanically deactivated with the switch located on the side of the device.
What audio formats does my Thomson 260 Pro support via HDMI to the amplifier?	The Streaming Box 260 Pro supports most digital audio formats.
Why is there no signal on my TV even though my Streaming Box 260 Pro is connected to it with an HDMI cable?	You may have selected the wrong input source on the TV. After switching to the correct HDMI port, it takes a few seconds to receive a signal from the Streaming Box 260 Pro.

The TV does not display a 4K UHD picture.	The quality depends on the media and the input source. Poor image quality can be caused by the following reasons:  - you are watching low-resolution content; - you are using a cable that does not support 4K UHD; - your TV does not support 4K UHD.
Do I need a Google account to use my Thomson 260 Pro?	A Google account is required to set up the Streaming Box 260 Pro. You must be signed into your Google account on your Streaming Box 260 Pro to access the Google Play store, Hey Google and favourite content offerings of streaming applications.
I can't find a particular app on the Google Play Store, even though I can download it to my phone.	Some apps that are available in the Google Play store for mobile devices such as smartphones and tablets are not available for Google TV devices for legal reasons.
Can I create or edit my Google account on my Thomson 260 Pro?	No, you need to use your mobile or PC to create and edit your Google account.
What are the internet requirements for my Thomson 260 Pro	The Streaming Box 260 Pro works well with standard internet connection. However, you will have better experience the faster the Internet connection is. Please note, that the more devices are connected to your home network, the less broadband you have for your Streaming Box 260 Pro.
What Bluetooth devices can be connected to Thomson 260 Pro?	You can connect audio devices, such as headphones and speakers as well as input devices, like keyboard or gamepad, to the Streaming Box 260 Pro via Bluetooth.
How do I use Google Assistant?	From the Android Home menu, press the Google Assistant button on the Streaming Box 260 Pro remote control. You can search for any content. All content related to your question will appear in the list.
How can I find out that a new software version is available for my streaming device?	Software updates for the Streaming Box 260 Pro are automatic. If there are available updates for installed apps, a notification will appear on the Home Screen. Navigate to the Notification and press OK to read it.
Can my Thomson 260 Pro also be used as an IPTV box?	Yes, the Streaming Box 260 Pro can be used for IPTV. In order to do so, you need to download a preferred IPTV application.

## 16. Technical Specifications

### 16.1. Audio & Video

Display resolution: 4K Ultra HD

Video resolution: 4Kx2K@60fps, 1080p, 1080i, 720p, 576p, 576i, 480p, 480i

Audio decoding: Dolby Atmos, Dolby Digital, Dolby Digital Plus

### 16.2 System & Memory

Operating system: Google TV – Android TV 14 OS v.14

Chipset: Amlogic S905X5M-B

CPU: Quad-Core Cortex-A55

GPU: ARM G310 V2

DRAM: DDR4 4GB

Flash eMMC 64GB

### 16.3 Ports

1x Ethernet (RJ-45) 1 Gbit/s

1x S/PDIF (optical)

1x HDMI 2.1

1x DC/IN

2x USB 2.0 port (5 V, max. 500 mA)

## **16.4 Wireless Connectivity**

Built-in Wi-Fi: 802.11 a/b/g/n/ac/ax, 2.4 GHz /5 GHz  
2T2R Bluetooth: yes

## **16.5 Compatibility**

HD, FHD and UHD TVs with HDMI compatible port  
Bluetooth Mouse & Keyboard  
Bluetooth game controller

Power supply: AC 100 - 240 V AC ~ 50/60 Hz

Input voltage: Power adapter DC 12 V= 1 A

Power consumption working: max. 12 W

Power consumption in standby: 2.0 W

RF Maximum Transmit Power: 2.4 GHz: max. 19.21 dBm 5GHz: max. 21.43 dBm

Operating temperature: 0 ~ +40 °C

Storage temperature: -10 ~ +60 °C

Dimensions (W x D x H in mm): 110 x 110 x 23

Weight (in kg): 0.116

## 17. European Agency Information

Company: Streamview GmbH  
 Address: Franz-Josefs-Kai 1, 1010 Vienna, Austria

### Licenses

Subject to alterations. In consequence of continuous research and development technical specifications, design and appearance of products may change. Please note, that the download speed depends on your Internet connection and some apps might not be available in all countries. Membership for streaming services may be required. Google TV is the name of this device's software experience and a trademark of Google LLC. Google, YouTube, Google Cast and YouTube Music are trademarks of Google LLC. Google Assistant is not available in certain languages and countries. Availability of services varies by country and language. Netflix is a registered trademark of Netflix, Inc. Netflix streaming membership required. Netflix is available in selected countries. More information can be found at [www.netflix.com](http://www.netflix.com). Apple TV is a trademark of Apple Inc., registered in the U.S. and other countries and regions. Wi-Fi is a registered trademark of Wi-Fi Alliance®. The Bluetooth® word mark and logos are registered trademarks owned by Bluetooth SIG, Inc. and any use of such marks is under license. The terms HDMI and HDMI High-Definition Multimedia Interface, and the HDMI logo are trademarks or registered marks of HDMI Licensing Administrator, Inc. in the United States and other countries. Dolby, Dolby Vision, Dolby Atmos, Dolby Audio, and the Double-D symbol are trademarks of Dolby Laboratories Licensing Corporation. Manufactured under license from Dolby Laboratories. Confidential unpublished works. Copyright © 1992–2026 Dolby Laboratories. Disney+ subscription required, see terms at <https://www.disneyplus.com>. ©2026 Disney and its related entities. ©2026 Amazon.com, Inc. or its affiliates. Amazon, Prime Video, and all related marks are trademarks of Amazon.com, Inc. or its affiliates. Amazon Prime membership or Prime Video fees apply. See [primevideo.com/terms](http://primevideo.com/terms) for details. All other products, services, companies, trademarks, trade or product name and logos referenced herein are the property of their respective owners. All rights reserved. ©2026 StreamView GmbH, Franz-Josefs-Kai 1, 1010 Vienna, Austria, [contact@streamview.com](mailto:contact@streamview.com). This product has been manufactured and sold under the responsibility of StreamView GmbH. THOMSON, and the THOMSON logo are trademarks used by StreamView GmbH – further information at [www.thomson-brand.com](http://www.thomson-brand.com).

Data Protection: The application providers and the providers of the services may collect and use technical data and related information, including but not limited to technical information about this device, system and application software and peripherals. The application providers and the providers of the services may use such information to improve products or to provide services or technologies, which do not personally identify you. Additionally, some third-party services, already provided in the device or installed by you after purchasing the product, may request a registration with your personal data. Some services may collect personal data even without providing additional warnings. StreamView cannot be held liable for a possible breach of data protection by third-party services.



	AT	BE	BG	CH	CY	CZ	DK	DE	EE	EL	ES	FI
	FR	HR	HU	IE	IS	IT	LI	LT	LU	LV	MT	NL
	NO	PL	PT	RO	SE	SI	SK	TR	UK(NI)			

	UK